

THIS DOCUMENT IS THE PROPERTY OF
KEYSTONE ELECTRONICS CORP. AND
SHALL NOT BE REPRODUCED, DISTRIBUTED
OR USED AS A BASIS FOR MANUFACTURE
WITHOUT PRIOR WRITTEN PERMISSION
FROM KEYSTONE ELECTRONICS CORP.

ACTUAL SIZE

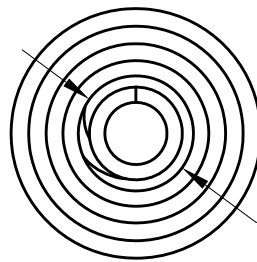

$+.005 [+0.15]$
 $-.000 [-.000]$
 $\varnothing.300 [\varnothing7.62]$ DIA.

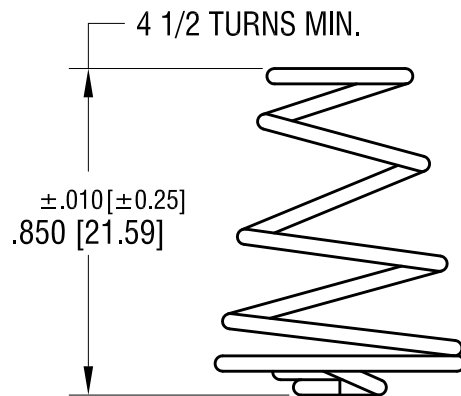

SURFACE MUST BE FLAT
& PERPENDICULAR TO AXIS

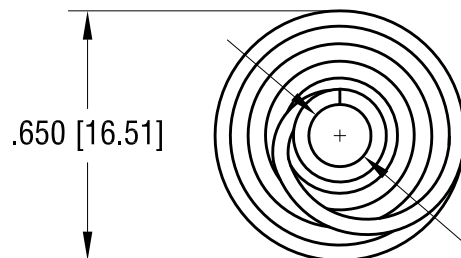

$.650 [16.51]$

$+.002 [+0.05]$
 $-.003 [-0.07]$
 $\varnothing.162 [\varnothing4.11]$ DIA.

KEYSTONE ELECTRONICS CORP.

www.keyelco.com • ASTORIA, N.Y. 11105-2017 • Tel (718) 956-8900

PART NAME

COIL SPRING

MATERIAL

.040 [1.02] DIA. MUSIC WIRE

FINISH

NICKEL PLATE

DRN BY

BOONE

DATE

11.11.93

APP'D

LN

SCALE

2X

12.18.12 CHANGE AS PER ECN 12-159

A

TOLERANCES

INCH [MM]
DECIMAL $\pm .005 [\pm 0.13]$

CODE

C

DWG NO.

211-D

ANGULAR $\pm 1^\circ$
UNLESS OTHERWISE SPECIFIED

DATE

DESCRIPTION

REV.