

DATE	DESCRIPTION	REV.
12.23.04	CHANGE AS PER ECN 04-174	L
8.17.09	CHANGE AS PER ECN 09-117	M

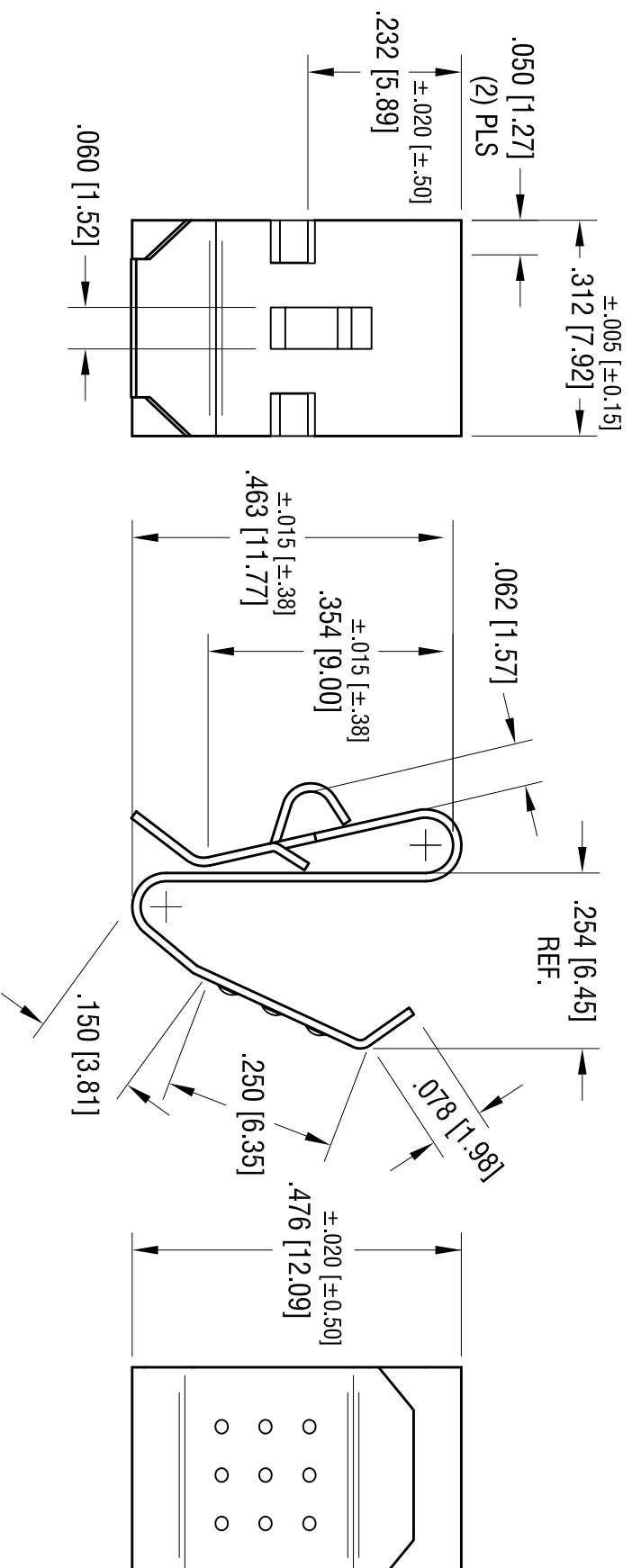

- NOTE:
1. HEAT TREAT TO SPRING TEMPER.
 2. DESIGNED TO CLIP OVER PANELS FROM .060 [1.52] THRU .070 [1.78] THK.

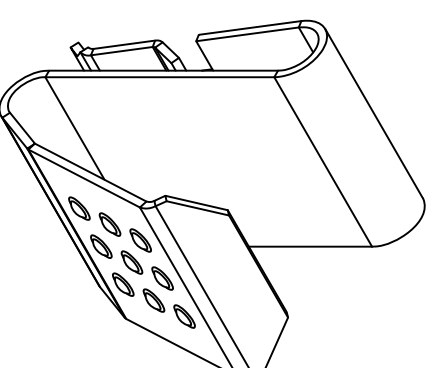

KEYSTONE ELECTRONICS CORP.			
ASTORIA, N.Y. 11105-2017			
PART NAME		SINGLE A-A CONTACT	
MATERIAL			
.012 [.30] THK ANNEALED SPRING STEEL			
FINISH		NICKEL PLATE	
DRN BY	DATE	APP'D	SCALE
BOONE	4.27.83	LN	4X
TOLERANCES		CODE	DWG NO.
INCH	[MM]	C	209
DECIMAL	± .010 [± 0.25]		
ANGULAR	± 1°		
UNLESS OTHERWISE SPECIFIED			