

THIS DOCUMENT IS THE PROPERTY OF
KEYSTONE ELECTRONICS CORP. AND
SHALL NOT BE REPRODUCED, DISTRIBUTED
OR USED AS A BASIS FOR MANUFACTURE
WITHOUT PRIOR WRITTEN PERMISSION
FROM KEYSTONE ELECTRONICS CORP.

MOUNTING LAYOUT

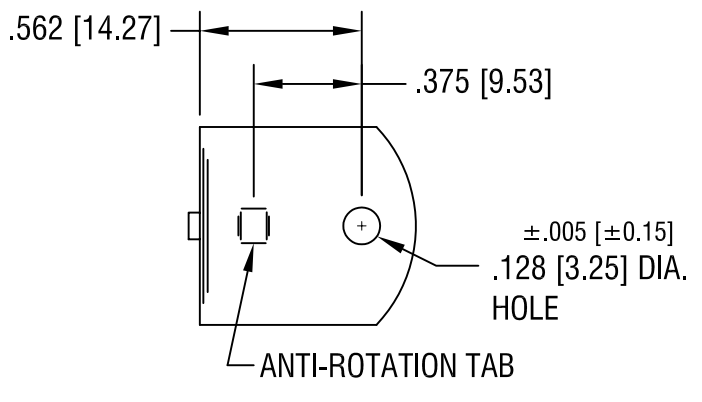
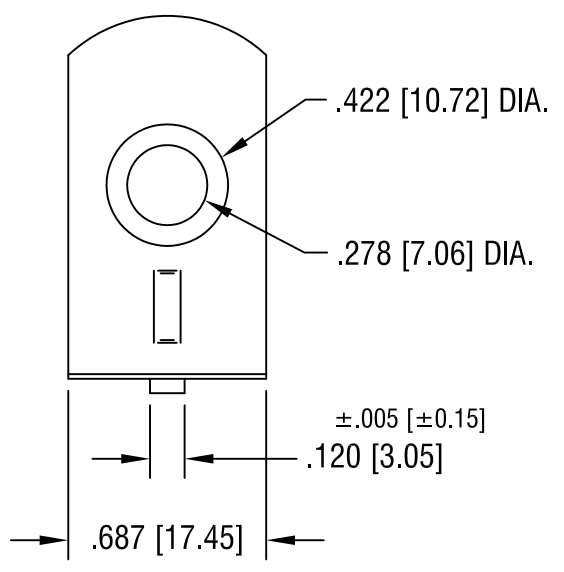
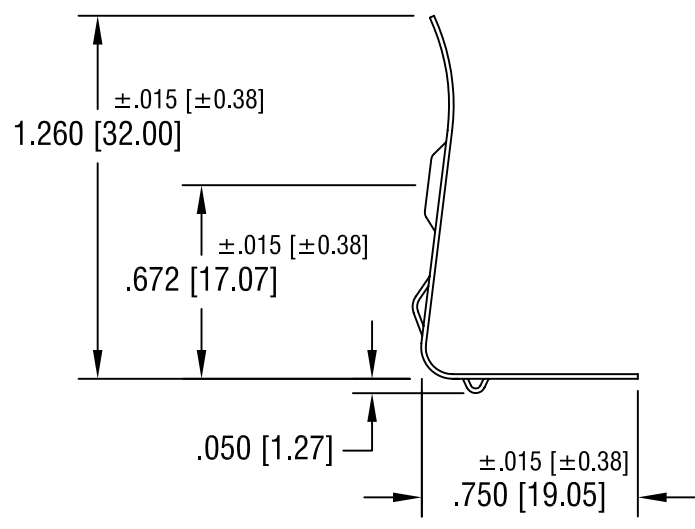
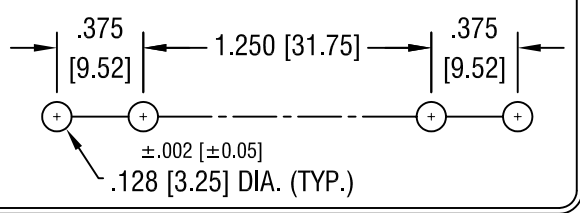

NOTE:
1. HEAT TREAT TO SPRING TEMPER.

KEYSTONE ELECTRONICS CORP.			
ASTORIA, N.Y. 11105-2017			
PART NAME		'D' CELL CLIP	
MATERIAL			
.016 [.40] TH'K ANNEALED SPRING STEEL			
FINISH		DRN BY	DATE
NICKEL PLATE		BOONE	1.29.82
		APP'D	SCALE
		LN	1.5X
TOLERANCES	INCH [MM]	CODE	DWG NO.
DECIMAL	±.010 [±0.25]	C	208
ANGULAR	± 1°		
UNLESS OTHERWISE SPECIFIED			

4.4.00	CHANGE AS PER ECN 00-015	C
DATE	DESCRIPTION	REV.