

90mm

90mm



USER GUIDE PROTECH H0717

Please read this manual carefully before using the product as it contains important operation information.

FAVOUR

- 1000 LUMENS**
- WHITE LED - HIGH**
- WHITE LED - LOW**
- WHITE LED - 2Hz FLASHING**
- RED LED - ON**
- 1M DROP IMPACT**
- FREE PROJECTION ANGLE**
- USB RECHARGEABLE**
- 45H**
- WHITE LED - MED**
- WHITE LED - 8Hz FLASHING**
- WHITE LED - SOS FLASHING**
- RED LED - 3Hz FLASHING**
- WATER RESISTANT**
- RED REAR LIGHT**
- BATTER POWER INDICATOR / LOW POWER WARNING**

ANSI FL 1

ANSI FL 1					
HEADLIGHT HIGH	1000 Lumens	13500cd	230m	3h	
HEADLIGHT MED	450 Lumens	6500cd	160m	8h	
HEADLIGHT LOW	20 Lumens	400cd	40m	45h	
HEADLIGHT 8Hz FLASHING*	NA	NA	NA	14h	✓
HEADLIGHT 2Hz FLASHING*	NA	NA	NA	22h	✓
HEADLIGHT SOS FLASHING*	NA	NA	NA	24h	
REAR LIGHT ON	NA	NA	NA	42h	
REAR LIGHT 3Hz FLASHING*	NA	NA	NA	60h	

* Flashing mode specifications cannot be measured by ANSI FL1 Standard.
* Flashing mode runtime is based on measurement of battery capacity charge only.

HOW TO RECHARGE DIAGRAM

When the headlight becomes noticeably dim, switch off the unit and recharge the battery as soon as possible.

Battery Type 1 x 3.7V 2600mAh 18650 Li-ion Rechargeable Battery
Charging Time 4hrs

- Connect the rear light to your PC, or an approved USB adaptor, a solar panel, a portable power bank or any other charging devices with an USB outlet, with the micro USB cable.
- The Red LED indicator will light up to indicate charging has started. The Green LED indicator will light up when the battery has been fully charged.

Note:

- The battery will reach full performance only after a few complete charging & discharging cycles.
- DO NOT leave the rear light in charging status (with power connected) continuously for more than five days, as this cause a reduction in battery efficacy.

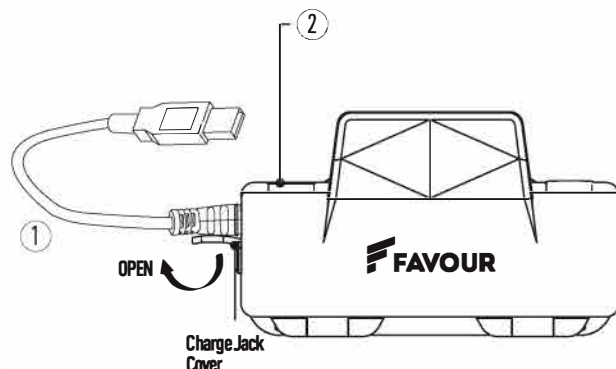

ENGLISH SPECIFICATIONS

FEATURES
- XM-L2 Cree White LED - Up to 1000 Lumens
- Tactical Reflector produces 230m Beam Throw
- Electronic Switch - One click Activation for 3 Brightness Levels & 3 Flashing Modes
- Direct Plug-In Recharge by Micro USB
- LED Indicator Shows Battery Capacity & Charging Status
- Red Rear Light on Battery Case for Safety Indication
- Regulated Circuit with Protection from Over-charging & Over-discharging
- Inside Security is Protected by Helium Clips Includer
- Water Resistant

CHARGING INFO
4hrs Charging Time
Red LED ON - Charging
Green LED ON - Fully Charged

BATTERY CYCLE
500 Cycles

BATTERY POWER INDICATOR
Green LED ON - High Power
Amber LED ON - Medium Power
Red LED ON - Low Power

BULBTYPE
1 x XM-L2 Cree White LED

OPERATION
Headset Press for FLASHING Output
(At any mode) CONSTANT ON Output
(Long press to switch to FLASHING Output)
CONSTANT ON Output
HIGH + MED + LOW + OFF
FLASHING Output
RED FLASHING + 8Hz FLASHING
+ SOS FLASHING + OFF
(Press 5/5/1 stays in any mode over 3 seconds)
Rear Light ON > 3Hz FLASHING + OFF

BATTERY TYPE
Built-in 1 x 3.7V 2600mAh 18650 Li-ion Rechargeable Battery (Included)

WEIGHT
271g (With Battery)

BUILD REPLACEMENT
LED never needs to be replaced.

WARNING
- Do NOT touch the contacts or the LED light for more than few seconds.
- Do NOT allow children to use LED light unless under the supervision of an adult.
- Do NOT leave the LED light unattended. The LED light can become extremely hot. Ensure sufficient ventilation when the LED light is used. Ensure the LED light is completely cooled off before touching its heat.
- Do not disassemble the contacts or the LED light under any condition.
- Reverse charging is not acceptable.
- Charge before use, although the battery is delivered in a charged state.
- Do not short-circuit the battery. Permanent damage to the battery may result.
- Never insert any foreign metallic objects into the charge jack's headlight.
- (At any mode) CONSTANT ON Output
(Long press to switch to FLASHING Output)
CONSTANT ON Output
HIGH + MED + LOW + OFF
FLASHING Output
RED FLASHING + 8Hz FLASHING
+ SOS FLASHING + OFF
(Press 5/5/1 stays in any mode over 3 seconds)
Rear Light ON > 3Hz FLASHING + OFF

ACCESSORIES
Headset Helium Clips/2pcx3x Micro USB Cable

SEE
Headlight: 67mm x 44mm x 53mm
Battery Case: 64mm x 49mm x 48mm

REAR LIGHT
ON > 3Hz FLASHING + OFF

ITALIANO SPECIFICHE

CARATTERISTICHE
- XM-L2 Cree LED Bianco - Fino a 1000 lumen
- Il riflettore produce un fascio luminoso fino a 230m
- Interruttore elettronico - Attivazione con un click per 3 livelli di luminosità e 3 modalità di lampeggio
- Ricaricabile tramite cavo micro USB
- LED indicatore per livello di carica
- La luce posteriore serve da indicazione sulla capacità della batteria

BATTERIA
- 1x XM-L2 Cree White LED - Up to 1000 Lumens
- Tactical Reflector produces 230m Beam Throw
- Electronic Switch - One click Activation for 3 Brightness Levels & 3 Flashing Modes
- Direct Plug-In Recharge by Micro USB
- LED Indicator Shows Battery Capacity & Charging Status
- Red Rear Light on Battery Case for Safety Indication
- Regulated Circuit with Protection from Over-charging & Over-discharging
- Inside Security is Protected by Helium Clips Includer
- Water Resistant

SOSTITUIRE DELLA LAMPADA
- Il LED deve essere sostituito separatamente.

AVVERTENZE
- Non toccare la luce emessa dal LED direttamente sulla cute o altri organi sensibili.
- Non lasciare la batteria senza l'unità LED senza supervisione di un adulto.
- Non lasciare la batteria in carica per un tempo superiore ai 5 giorni di produzione.
- Assicurarsi che la batteria sia completamente raffreddata prima di toccarla.

RICARICA
- Tempo di carica di 4 ore
- LED rosso acceso - Lampeggio
- LED verde acceso - Carica completa

CICLI DI RICARICA
500 cicli

INDICAZIONE DELL'AVVIO DELLA BATTERIA
- LED rosso acceso - Lampeggio
- LED verde acceso - Lampeggio
- LED rosso acceso - Lampeggio

LAMPADINA
1 LED XM-L2 Cree luce bianca

ACCESSORI
2 clip per fascio elastico e cavo micro USB

DIMENSIONI
67mm x 44mm x 53mm
Scatola batteria: 64mm x 49mm x 48mm

PISTO
271g (Con Batteria)

FRANÇAIS SPECIFICATIONS

CARACTÉRISTIQUES
- XM-L2 Cree White LED - Up to 1000 Lumens
- Tactical Reflector produces 230m Beam Throw
- Electronic Switch - One click Activation for 3 Brightness Levels & 3 Flashing Modes
- Direct Plug-In Recharge by Micro USB
- LED Indicator Shows Battery Capacity & Charging Status
- Red Rear Light on Battery Case for Safety Indication
- Regulated Circuit with Protection from Over-charging & Over-discharging
- Inside Security is Protected by Helium Clips Includer
- Water Resistant

TYPE DE PILE
Pile intégrée au rétroéclairage rechargeable 1 x 3.7V 2600mAh 18650 Li-ion (Inclus)

ATTENTION
- Ne regardez jamais directement la lampe à LED pour éviter les brûlures.
- Ne laissez pas la batterie sans l'unité LED sans supervision d'un adulte.
- Ne laissez pas la batterie en charge pendant plus de 5 jours.
- Assurez-vous que la batterie est complètement refroidie avant de la toucher.

CHARGEMENT
Temps de charge - 4 heures
LED rouge ON - Charge en cours
LED vert ON - Charge terminée

CYCLES DE CHARGEMENT DE LA PILE
500 Cycles

INDICATEURS DE NIVEAU DE LA PILE
LED rouge ON - Puissance élevée
LED vert ON - Puissance moyenne
LED rouge ON - Puissance faible

TYPE D'AMPOULE
1 x XM-L2 Cree White LED

ACCESSOIRES
Clips de fixation par bandeau pour chaque Diode et câble avec connecteur micro USB

TAILLE
67mm x 44mm x 53mm
Boîte de la pile: 64mm x 49mm x 48mm

POIDS
271g (Pile comprise)

REEMPLACEMENT DE LA LAMPADINA
Le LED doit être remplacé séparément.

DEUTSCHE SPECIFIKATIONEN

EIGENSCHAFTEN
- XM-L2 Cree LED Weiss - Bis zu 1000 Lumen
- Der Reflektor erzeugt einen Lichtstrahl mit einer Reichweite von 230m
- Elektronischer Schalter - Einschaltung durch einen Klick zwischen 3 Lichtstufen und 3 Blinkmodi
- Direktes Aufladen über Micro USB
- LED-Indikator zeigt den Ladezustand und den Ladestatus
- Rotes Rücklicht auf dem Akkufachdeckel
- Regulierte Schaltung mit Schutz gegen Überladung und Überentladung
- Innen ist die Sicherheit durch Heliumklips geschützt
- Wasserdicht

WICHTIG!
- Auf keinen Fall das Gerät ins Feuer werfen oder zerlegen.
- Auf keinen Fall den Akku mit umgekehrter Polarität aufladen.
- Der Akku richtiger als fünf Tage unbenutzt aufladen (in das Stromnetz angeschlossen, ohne seine Ladungsfähigkeit direkt zu überprüfen).
- Vor Gebrauch aufladen, auch wenn der Akku schon geladen ist.
- Bei Gebrauch des Akkus in extremen Umgebungen (hohe oder niedrige Temperaturen, Feuchtigkeit, etc.) sollten sie nicht verwendet werden.

AKKUFACHDECKEL
Grüne LED an - Akkuladung hoch
Rote LED an - Akkuladung niedrig

DIODE
1 x XM-L2 Cree LED

ZUSÄTZLICHE
2 Klammern für das Stromband und Micro-USB-Kabel

GRÖÖÖ
Länge: 67mm x 44mm x 53mm
Akkukasten: 64mm x 49mm x 48mm

GEWICHT
271g (Mit Akku)

LEBENSZEIT
Die LED braucht nicht ersetzt zu werden.

ESPAÑOL ESPECIFICACIONES

CARACTERÍSTICAS
- XM-L2 Cree LED Blanco - Hasta 1000 Lúmenes
- Reflector táctil produce un haz de luz de 230m de alcance
- Interruptor electrónico - Una click activación para 3 niveles de brillo y 3 modos de parpadeo
- Recarga directa por Micro USB
- LED indicador muestra el estado de carga
- Luz trasera roja en el compartimento de la batería
- Circuito de protección contra carga y descarga excesiva
- Seguridad interna por protección de clips de helio
- A prueba de agua

ADVERTENCIA
- No deje caer o arrojar el LED durante pocos segundos.
- No permita que se vea el rojo de la luz LED en la supervisión de adulto.
- No deje la batería sin supervisión de un adulto.
- No deje la batería en estado de carga por más de 5 días.
- Asegúrese de que la batería se haya enfriado completamente antes de tocarla.
- No deje la batería en estado de carga por más de 5 días.
- Asegúrese de que la batería se haya enfriado completamente antes de tocarla.

INDICADOR DE POTENCIA DE LA BATERÍA
Luz roja LED ON - Potencia alta
Luz verde LED ON - Potencia media
Luz roja LED ON - Potencia baja

TIPO DE BOMBILLA
1 x XM-L2 Cree LED Blanco

ACCESORIOS
Cables diodos (2) y cable Micro USB

TAMANO
Luz: 67mm x 44mm x 53mm
Caja de la batería: 64mm x 49mm x 48mm

PESO
271g (Con Batería)

CAMBIO DE LA BOMBILLA
La luz LED no necesita ser sustituida.

PORTUGUÊS ESPECIFICAÇÕES

CARACTERÍSTICAS
- XM-L2 Cree LED Branco - até 1000 Lumens
- Reflector táctil produz um feixe de luz de 230m de alcance
- Interruptor eletrônico - Uma click activação para 3 níveis de brilho e 3 modos de piscar
- Recarga direta por Micro USB
- LED indicador mostra o estado de carga
- Luz traseira vermelha no compartimento da bateria
- Circuito de proteção contra carga e descarga excessiva
- Segurança interna por proteção de clipe de hélio
- À prova de água

ATENÇÃO
- Não deixe cair ou jogar o LED mais que alguns segundos.
- Não permita que a luz vermelha do LED seja visível sob supervisão de adulto.
- Não deixe a bateria sem supervisão de um adulto.
- Não deixe a bateria em estado de carga por mais de 5 dias.
- Certifique-se de que a bateria esteja completamente resfriada antes de tocá-la.
- Não deixe a bateria em estado de carga por mais de 5 dias.
- Certifique-se de que a bateria esteja completamente resfriada antes de tocá-la.

INDICADOR DE POTÊNCIA DA BATERIA
Luz LED vermelha ON - Potência alta
Luz LED verde ON - Potência média
Luz LED vermelha ON - Potência baixa

TIPO DE LÂMPADA
1 x XM-L2 Cree LED Branco

TAMANO
Luz: 67mm x 44mm x 53mm
Caja de bateria: 64mm x 49mm x 48mm

PESO
271g (com pilhas)

REPOSIÇÃO DE LÂMPADA
O LED não precisa de ser substituído

NEDERLANDS SPECIFICATIE

KENMERKEN
- XM-L2 Cree LED lamp wit - tot 1000 lumen
- De reflector produce een lichtstraal van 230m
- Elektronisch schakeltoets - 1 klik activatie voor 3 lichtniveaus & 3 flitsmodi
- Directe oplading via micro USB
- LED indicator voor batterijcapaciteit & ladingstatus
- Rood achterlicht op het batterijcompartiment voor veiligheidsaanduiding
- Gereguleerd circuit met beveiliging tegen overlading & overontlading
- Binnen de behuizing is het apparaat beschermd door helium clips
- Waterdicht

OPMERKINGEN
- Niet laten vallen ofwerpen van de LED meer dan een paar seconden.
- Niet toestaan dat de rode licht van de LED zichtbaar is onder toezicht van een volwassene.
- Niet de batterij zonder toezicht van een volwassene.
- Niet de LED lamp in de ladingstatus laten staan voor meer dan 5 dagen.
- Zorg ervoor dat de LED lamp volledig is afgekoeld voor u de top ervan aanraakt.
- Verwijder de batterijen als de LED lamp langere tijd niet gebruikt wordt of de accu's leeg zijn.

INDICATOR BATTERIJNIVEAU
Groen LED lampje brandt - maximaal
Geel LED lampje brandt - gemiddeld
Rood LED lampje brandt - minimaal

TIPO DE LAMPADA
1 x XM-L2 Cree LED lamp wit

ACCESORIËN
Hoofddoel met helium clips (2x3x3) Micro USB kabel (2x3x3)

AFMETINGEN
Hoofddoel: 67 mm x 44 mm x 53 mm
Batterijcompartiment: 64 mm x 49 mm x 48 mm

GEWICHT
271g (inclusief batterij)

LAMP VERVANGEN
De LED lamp hoeft nooit te worden vervangen.

size:(W)630mm x (H)90mm